

Mathematics Assessment Project
CLASSROOM CHALLENGES
A Formative Assessment Lesson

Estimating and Sampling: Jellybeans

Mathematics Assessment Resource Service
University of Nottingham & UC Berkeley
Beta Version

For more details, visit: <http://map.mathshell.org>
© 2013 MARS, Shell Center, University of Nottingham
May be reproduced, unmodified, for non-commercial purposes under the Creative Commons license
detailed at <http://creativecommons.org/licenses/by-nc-nd/3.0/> - all other rights reserved

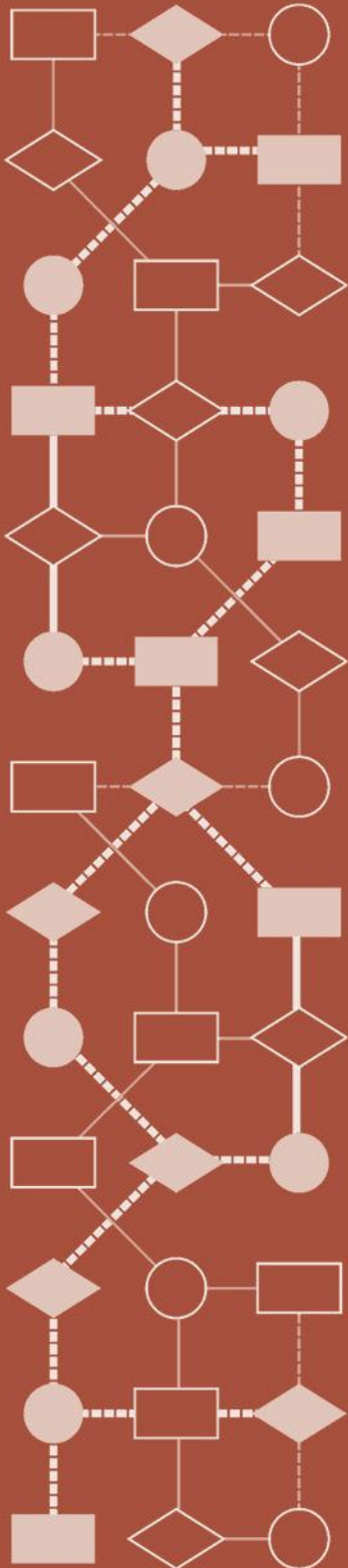

Estimating and Sampling: *Jellybeans*

MATHEMATICAL GOALS

This lesson unit is intended to help you assess how well students are able to:

- Model a situation mathematically, justifying any assumptions made.
- Estimate unknown values/missing information when solving a problem.
- Calculate volumes of three-dimensional objects.
- Use an appropriate sampling method to draw conclusions about a population.

COMMON CORE STATE STANDARDS

This lesson relates to the following *Mathematical Practices* in the *Common Core State Standards for Mathematics*:

2. Reason abstractly and quantitatively.
3. Construct viable arguments and critique the reasoning of others.
4. Model with mathematics.

This lesson gives students the opportunity to apply their knowledge of the following *Standards for Mathematical Content* in the *Common Core State Standards for Mathematics*:

- 8-G: Solve real-world problems involving volume of cylinders, cones, and spheres.

INTRODUCTION

The lesson unit is structured in the following way:

- Before the lesson, students attempt the *Jellybeans* task individually. You then assess their responses and formulate questions that will prompt students to review their work.
- At the start of the lesson, students think individually about their responses to the questions set.
- Next, students work in small groups to combine their thinking and work together to produce a collaborative solution to the *Jellybeans* task, in the form of a poster.
- In the same small groups, students evaluate and comment on sample responses, identifying the strengths and weaknesses in each approach and comparing them with their own work.
- In a whole-class discussion students compare and evaluate the methods they have seen and used.
- In a follow-up lesson, students reflect on their work and what they have learned.

MATERIALS REQUIRED

- Each student will need a copy the assessment task: *Jellybeans* (printed in color, if possible), a copy of the questionnaire *How Did You Work?* and some plain paper to work on.
Calculators should be made available on request.
- Each small group of students will need a large sheet of paper and copies of *Sample Responses to Discuss*.
- There is a projector resource to support whole-class discussions.

TIME NEEDED

20 minutes before the lesson for the assessment task, a 95-minute lesson, and 15 minutes in a follow-up lesson (or for homework). Timings given are only approximate. Exact timings will depend on the needs of the class.

BEFORE THE LESSON

Assessment task: *Jellybeans* (20 minutes)

Have students complete this task, in class or for homework, a few days before the formative assessment lesson. This will give you an opportunity to assess the work and to find out the kinds of difficulties students have with it. You should then be able to target your help more effectively in the follow-up lesson.

Briefly introduce the task.

Have you ever seen a competition where you have to guess the number of candies in a jar and there is a prize for the person with the closest estimate?

If students are familiar with the context, ask them to describe what it was like:

What did the jar look like?

What kind of candies were they?

If students have entered a competition of this type, ask them to describe their strategies for 'guessing' the number of candies. Explain that today's task is about estimating the number of candies in a jar using different strategies that involve some mathematics.

Give each student a copy of the assessment task *Jellybeans* and some plain paper to work on. Provide a color version if possible and if this is not possible students should still be able to pick out the black jellybeans from a black and white image. Otherwise use the projected picture.

Display Slide P-1 of the projector resource.

*Spend twenty minutes on your own, devising strategies for estimating the **total number of jellybeans in the jar** and the **number of black jellybeans in the jar**.*

Use the plain paper to show your work and explain any choices you make about your methods.

You may want to refer to the color version of the diagram (projected) when estimating the number of black jellybeans.

It is important that, as far as possible, students work on the task without your assistance. If students are struggling to get started then ask questions that help them understand what is required, but make sure you do not do the task for them.

Students who sit together often produce similar answers and then when they come to compare their work, they have little to discuss. For this reason we suggest that when students do the task individually, you ask them to move to different seats. Allow them to return to their usual seats at the beginning of the formative assessment lesson. Experience has shown that this produces more profitable discussions.

When all students have made a reasonable attempt at the task, tell them that they will have time to revisit and revise their solutions later.

Jellybeans



Joseph is at the fair and wants to enter the 'Jellybean Guessing Contest'.
The jar is 11.5cm tall, 5cm wide and 5cm deep.

- What estimate for the **total number** of jellybeans should Joseph give?
- What estimate for the number of **black** jellybeans should he give?

Explain your answer showing all your work.

Assessing students' responses

Collect students' responses to the task. Make some notes on what their work reveals about their current levels of understanding and their different problem solving approaches.

We suggest that you do not score students' work. The research shows that this will be counterproductive as it will encourage students to compare their scores and distract their attention from what they can do to improve their mathematics.

Instead, help students to make further progress by summarizing their difficulties as a series of questions. Some suggestions for these are given in the *Common issues* table on the next page. These have been drawn from common difficulties observed in trials of this unit.

We suggest you make a list of your own questions, based on your students' work. We recommend you either:

- Write one or two questions on each student's work, or
- Give each student a printed version of your list of questions, and highlight the questions for each individual student.

If you do not have time to do this, you could select a few questions that will be of help to the majority of students and write these on the board when you return the work to the students at the beginning of the lesson.

Common issues**Suggested questions and prompts**

<p>Counts the visible jellybeans in the jar</p> <p>For example: The student counts the number of visible jellybeans in the jar and doubles it as an estimate of the total number of jellybeans.</p> <p>Or: The student counts the number of visible black jellybeans and uses this as an estimate for the number of black jellybeans.</p>	<ul style="list-style-type: none"> • How could you take into account the number of jellybeans in the center of the jar? • Can you think of a more efficient strategy that you could use on a much larger jar? • What assumption have you made about the number of black jellybeans in the jar?
<p>Calculates the volume of the jar</p> <p>For example: The student models the jar as a right rectangular prism and estimates the number of jellybeans as $11.5 \times 5 \times 5 = 287.5$ (approximately 287 jellybeans).</p>	<ul style="list-style-type: none"> • Can you explain your calculation? What have you worked out? What are you trying to find? • What assumption have you made?
<p>Calculates the surface area of the jar</p> <p>For example: The student calculates the area of the circular lid and the square base and adds these to the area of four 11.5cm by 5cm sides to give an estimate for the number of jellybeans.</p>	<ul style="list-style-type: none"> • Can you explain how your calculations give you an estimate for the number of jellybeans? • Does your method take into account the number of jellybeans in the center of the jar?
<p>Uses an unrealistic estimate for the size of a jellybean</p>	<ul style="list-style-type: none"> • Can you compare the size of a jellybean to something that you know the measurements of? Are your estimations for the size of a jellybean realistic?
<p>Takes an unrepresentative sample</p> <p>For example: The student considers the section of the jar where three black jellybeans can be seen clustered together and uses this to estimate the total number of black jellybeans in the jar.</p>	<ul style="list-style-type: none"> • Is your sample representative of the distribution of black jellybeans in the whole jar? • How could you check the accuracy of your estimate?
<p>Assumes same proportion of each color jellybean in the jar</p> <p>For example: The student identifies the number of different colored jellybeans in the jar and divides their estimate for the total number of jellybeans by this number to give the number of black jellybeans in the jar.</p>	<ul style="list-style-type: none"> • What assumption have you made about the proportions of different colored jellybeans in the jar? How could you check this assumption?
<p>Gives an answer with no calculations shown or little explanation</p>	<ul style="list-style-type: none"> • What mathematics have you done to get an estimate for the total number of jellybeans/number of black jellybeans? • How did you come up with this number for the total number of jellybeans/number of black jellybeans?
<p>Gives a value for the number of jellybeans that is not a whole number</p>	<ul style="list-style-type: none"> • What does this number represent? • Does your estimate make sense as the number of jellybeans in the jar?

SUGGESTED LESSON OUTLINE

Reviewing individual solutions to the problem (10 minutes)

Give each student a mini-whiteboard, a pen and an eraser and return their work on the *Jellybeans* task.

If you have not added questions to individual pieces of student work, either give each student a printed version of your list of questions with the questions that relate to their work highlighted or write your list of questions on the board so that students can select questions from the board that are appropriate to their own work.

Recall what we were working on previously. What was the task about?

I have looked at your work and have some questions I would like you to think about.

On your own, carefully read through the questions I have written. I would like you to use the questions to help you to think about ways of improving your work. Use your mini-whiteboards to make a note of anything you think will help to improve your work. You will be sharing these notes with a partner later on.

If mini-whiteboards are not available, students may want to use the back of their assessment task to jot down their ideas about ways to improve their work.

This is an opportunity for students to review their own work before working collaboratively on producing a group solution.

Whilst students are reviewing their work, it may be appropriate to ask individual students questions that help them to clarify their thinking.

You may also want to show the class Slide P-1 of the projector resource:



Collaborative small-group work: Making Posters (35 minutes)

Organize the class into groups of two or three students.

Today you are going to work together on the Jellybeans task to produce a joint solution that is better than your individual work.

Before students revisit the task, they need to discuss what they have learned from reviewing their individual solutions. This will enable them to decide which of their different approaches is better.

Show and explain to students Slide P-2 of the projector resource:

Sharing Individual Solutions

1. Take turns to share with your partner(s) your own individual solution to the task and the notes you made on your mini-whiteboard about how you might improve your work.
2. Listen carefully to each other, asking questions if you don't understand.
3. Notice any similarities or differences between the methods described.

Once students have had a chance to discuss their work, give each group a sheet of poster paper. Display Slide P-3 of the projector resource and explain to students how to work collaboratively:

Joint Solution: Making Posters

1. In your group agree on the best method for completing the problem.
2. Produce a poster that shows a joint solution to the *Jellybeans* task, that is better than your individual work.
3. State on your poster any assumptions you have made.
4. Give clear reasons for your choice of method.

While students are working in small groups you have two tasks: to note different student approaches to the task and to support student problem solving.

Note different student approaches

In particular, note whether students' original methods are the same or different. If they are different, how do they decide which method to use for their joint solution? Do they use a different method to check that their estimate is reasonable? What are the reasons for their choice of method? In what ways have they modeled the jar and the jellybeans? Are students aware of any assumptions they have made? Some students may not introduce sampling as a method of estimating the number of jellybeans. If they do, how do they choose their sample? Is their sample representative of the population? Do they look at more than one section of the jar within their sampling?

Support student problem solving

If students are struggling to produce a joint solution to the task, try not to make suggestions that move them towards a particular approach to the task. Instead, ask questions to help students clarify their thinking, encouraging them to identify the strengths and weaknesses of the methods employed in their individual solutions. Can any of these methods be improved to produce a group solution that is better than the original individual response? Can they think of any other approaches to try?

If several students in the class are struggling you might want to write a relevant question on the board or hold a brief whole-class discussion:

What have you done that you both [all] agree on?

What assumptions have you made?

What else do you need to find out?

Have you used all the information given in the task?

What do you now know that you didn't know before?

You may also want to use some of the questions in the *Common issues* table to support your own questioning. The purpose of these questions is to help students to track and review their problem solving strategies. They should be encouraged to give reasons for the choices they have made.

Sharing Posters (10 minutes)

Once students have finished their posters, ask them to share their work by visiting another group. This gives the students the opportunity to engage at a deeper level with the mathematics and encourages a closer analysis of the work than may be possible by students presenting their posters to the whole class.

It may be helpful for students to jot down on their mini-whiteboards their estimates for the total number of jellybeans and number of black jellybeans in the jar before they visit another group.

Show Slide P-4 and explain how students are to share their work:

Sharing Posters
<ol style="list-style-type: none">1. One person from each group get up and visit a different group.2. If you are staying with your poster, explain your work to the visitor, giving reasons for your choice of method.3. If you are the visitor, look carefully at the work, asking clarifying questions to help you to understand the method used.4. Discuss whether or not the method described on the poster is similar to the visitor's method.5. Compare your estimates for the total number of jellybeans in the jar and the number of black jellybeans.

Collaborative analysis of Sample Responses to Discuss (20 minutes)

Once students have had sufficient time to discuss their joint solutions, give each group copies of the *Sample Responses to Discuss*.

It may not be appropriate, or there may not be enough time, for all students to analyze all three sample responses. Each response models the situation differently and so depending on the progress already made on the task, it may be appropriate to issue different sample responses to different groups. For example, groups that have relied solely on counting might benefit from looking at Ruth's or James' solution.

Display and explain to students Slide P-5 of the projector resource:

Sample Responses to Discuss
<ol style="list-style-type: none">1. Read each piece of sample student work carefully.2. Try to understand what they have done. You may want to add annotations to the work to make it easier to follow.3. Think about how the work could be improved. Take turns explaining your thinking to your partner.4. Listen carefully and ask clarifying questions.5. When your group has reached its conclusions, write your answers to the questions underneath the work.

This task gives students an opportunity to evaluate a variety of possible approaches to the task and to notice any differences and/or similarities with their own work.

Students should thoughtfully answer the questions below each piece of sample student work and be encouraged to think carefully about ways in which the work could be improved.

James breaks the contents of the jar down into layers and estimates that there are 25 jellybeans in one layer. The '5' labels on his diagram seem to relate to the number of jellybeans rather than the dimensions of the jar, but this is not clear.

James takes into account that the jar is narrower at the top and reduces the number of jellybeans in a layer accordingly.

It would appear that James ignores the dimensions of the jar completely and relies on counting jellybeans.

When estimating the number of black jellybeans in the jar James just counts the ones that he can see and assumes that there are not any others that cannot be seen.

Ruth correctly calculates the volume of a right rectangular prism with the dimensions given in the task but does not take into account the fact that the jar is not actually a prism. She may have been better to model the lower section as a right rectangular prism and the upper section as a cylinder.

Ruth has used the diagram and dimensions given to estimate the length of a jellybean. However, she has assumed that the jellybeans are lying end to end, even though it is clear from the picture of the jar and her diagram that this is not the case. She has used her estimate for the length of a jellybean to estimate the width and depth of a jellybean, by thinking about its proportions. When calculating the volume of a jellybean, (modeled too as a right rectangular prism) Ruth has made a calculation error and calculated $0.5 \times 0.5 \times 1$ to be 2.5 rather than 0.25. Using the correct value would result in an estimate of 1150 for the number of jellybeans suggesting that Ruth's estimate for the size of a jellybean is too small.

When estimating the number of black jellybeans, Ruth has assumed that the nine different colors will be in equal proportions within the jar.

One layer:

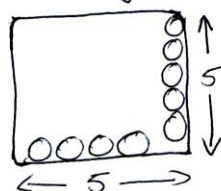

There are 7 layers like this so
 $5 \times 5 \times 7 = 175$
 jelly beans

Where the jar narrows at the top it is only 4×4 in a layer
 so $4 \times 4 \times 2 = 32$

Total number of jellybeans =
 $175 + 32 = 207$

I can see 7 black jelly beans in the jar.

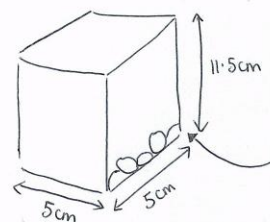

Volume of right rectangular prism
 $= 5 \times 5 \times 11.5 = 287.5 \text{ cm}^3$

Roughly 5 jellybeans fit along this length so length of jellybean = 1cm.

The width and depth of the jellybeans are roughly $\frac{1}{2}$ the length so 0.5cm

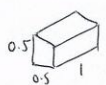

So volume of jellybean = $0.5 \times 0.5 \times 1 = 2.5$
 $\frac{287.5}{2.5} = 115$ jellybeans

There are 9 different colours of jellybean so
 $\frac{1}{9} \times 115$ will be black
 $\rightarrow = 12.8$ black jellybeans.

Charles models the jar as a cylinder and uses the dimensions given for the width/depth as the diameter of the circle. It may have been more appropriate to make an estimate for the diameter of the circle using the Pythagorean Theorem:

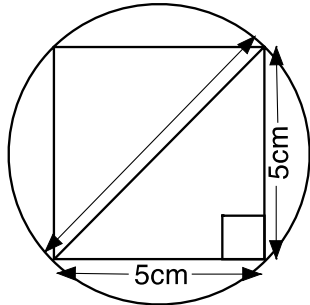

$$\text{Diameter} = \sqrt{5^2 + 5^2} = \sqrt{50} \text{ (approx. 7cm)}$$

Charles also models a jellybean as a cylinder, using realistic estimates for its dimensions. When dividing volumes to get an estimate for the number of jellybeans he rounds up rather than down.

When estimating the number of black jellybeans Charles fails to consider the jellybeans in the center of the jar.

The lid is round so the jar can be modeled as a cylinder.

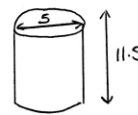

$$\begin{aligned} \text{Volume of cylinder} \\ &= \pi \times 2.5^2 \times 11.5 \end{aligned}$$

A jellybean can also be modeled as a cylinder with height 1.5cm and diameter 1cm



$$\text{Volume of jellybean} = \pi \times 0.5^2 \times 1.5$$

$$\text{Number of jellybeans} = \frac{\text{vol. of cylinder}}{\text{vol. of jellybean}} = 191 \frac{2}{3}$$

Can't have $\frac{2}{3}$ of a Jellybean $\therefore = 192$

I can see 2 sides of the jar and there are 7 black Jellybeans. There are 4 sides altogether so I guess the jar contains 14 black jellybeans.

Whole-class discussion: comparing different approaches (20 minutes)

Hold a whole-class discussion to consider the different approaches used within the sample responses. Look at each response in turn and ask students to comment on their strengths and weaknesses. It may be helpful to display Slides P-6 to P-8 during this discussion.

What did James/Ruth/Charles do?

What is unclear about James'/Ruth's/Charles' work?

How is James'/Ruth's/Charles' work similar/different to what you did?

Once you have discussed each piece of work, ask students to compare and evaluate the different methods.

What do you think is the best method for estimating the number of jellybeans? Why? What are the advantages of that method?

Did analyzing the responses enable anyone to see ways in which they could improve their own work?

Students should be encouraged to evaluate which method takes into account as many of the features of the jar and of a jellybean as possible as well as considering whether or not the estimate generated as a result is realistic, considering the size of the jar.

Follow-up lesson (or possible homework): individual reflection (15 minutes)

Once students have had a chance to discuss the sample responses as a whole class, distribute the questionnaire *How Did You Work?*

Ask students to spend a couple of minutes, individually, answering the questions.

Think carefully about your work this lesson and the different methods you have seen and used.

On your own, answer the review questions as carefully as you can.

Some teachers give this as homework.

SOLUTIONS

There are a number of ways of modeling this problem, but solutions should ideally include the following:

- A model of the task that includes calculations of volumes and/or sampling.
- An estimate for the dimensions of a jellybean (or the use of actual dimensions if it is decided to give students access to jellybeans during the lesson.)
- An estimate for the total number of jellybeans and number of black jellybeans in the jar given as a whole number with evidence of appropriate rounding.
- Any assumptions made stated clearly and justified.

Whether modeling a jellybean as a right rectangular prism or as a cylinder, a length of 1.5cm is reasonable.

When modeling the diameter or width and depth as 1cm the following estimates for the volume of a jellybean are produced:

Cylinder: With diameter 1cm and height 1.5cm gives a volume of 1.18 cubic centimeters (to 2 dp).

Right rectangular prism: With width and depth 1cm and height 1.5cm gives a volume of 1.5 cubic centimeters.

It should be noted however that there is a considerable empty volume in the jar, as the jellybeans do not stack. Some allowance should be added for this.

The following table may be helpful when reviewing student work:

Model and dimensions	Volume of jar (cubic centimeters)	Volume of jellybean (cubic centimeters)	Estimate for total number of jellybeans
Right rectangular prism H 11.5cm × W 5cm × D 5cm	287.5	1.18 (2dp) (modeled as cylinder)	244
Right rectangular prism H 11.5cm × W 5cm × D 5cm	287.5	1.5 (modeled as right rectangular prism)	191
Cylinder diameter 5cm	225.8 (1dp)	1.18 (2dp) (modeled as cylinder)	191
Cylinder diameter 5cm	225.8 (1dp)	1.5 (modeled as right rectangular prism)	150
Cylinder diameter $\sqrt{50}$	451.6 (1dp)	1.18 (2dp) (modeled as cylinder)	383
Cylinder diameter $\sqrt{50}$	451.6 (1dp)	1.5 (modeled as right rectangular prism)	301

Modeling the lower section of the jar as a right rectangular prism and the upper section of the jar as a cylinder gives the following results:

Model and dimensions	Volume of jar (cubic centimeters)	Volume of jellybean (cubic centimeters)	Estimate for total number of jellybeans
Right rectangular prism H 8cm × W 5cm × D 5cm + cylinder diameter 7 and height 3.5cm	334.69 (2dp)	1.18 (2dp) (modeled as cylinder)	284
Right rectangular prism H 8cm × W 5cm × D 5cm + cylinder diameter 7 and height 3.5cm	334.69 (2dp)	1.5 (modeled as right rectangular prism)	223

The table above provides one possible estimate for the dimensions of the right rectangular prism and cylinder. Alternative dimensions may of course be used and will result in different estimates.

All of the above models have limitations and some may provide better estimates than others but this will depend on how students justify their work. An estimate between 200 and 300 for the total number of jellybeans in the jar seems reasonable.

When estimating the number of black jellybeans students should ideally use a sampling method. It is easier to count the number of jellybeans in some parts of the jar than others and so this should be considered when choosing where to sample. Having sampled, the actual estimate for the number of jellybeans is likely to depend on a students' estimate for the total number of jellybeans in the jar. An estimate of between 15 and 25 seems reasonable.

Jellybeans

Guessing contest:
How many jellybeans are in the jar?



Tie Breaker:
How many **black** jellybeans are in the jar?

Joseph is at the fair and wants to enter the 'Jellybean Guessing Contest'.

The jar is 11.5cm tall, 5cm wide and 5cm deep.

- What estimate for the **total number** of jellybeans should Joseph give?
- What estimate for the number of **black** jellybeans should he give?

Explain your answers showing all your work.

Sample Responses to Discuss: James

One layer:

There are 7 layers like this so

$$5 \times 5 \times 7 = 175$$

jelly beans

Where the jar narrows at the top it is only 4×4 in a layer

so $4 \times 4 \times 2 = 32$

Total number of jelly beans =

$$175 + 32 = 207$$

I can see 7 black jelly beans in the jar.

What is misleading about James' diagram?

What advice would you give James about his estimate for the number of black jellybeans?

In what ways could James improve his work?

Sample Responses to Discuss: Ruth

Volume of right rectangular prism
 $= 5 \times 5 \times 11.5 = 287.5 \text{ cm}^3$

Roughly 5 jellybeans fit along this length so length of jellybean = 1cm.

The width and depth of the jellybeans are roughly $\frac{1}{2}$ the length so 0.5cm

So volume of jellybean = $0.5 \times 0.5 \times 1 = 2.5$

$\frac{287.5}{2.5} = 115$ jellybeans

There are 9 different colours of jellybean so $\frac{1}{9} \times 115$ will be black
 $\rightarrow = 12.8$ black jellybeans.

In what way has Ruth misinterpreted her diagram?

What calculation error has Ruth made?

What assumption has Ruth made when estimating the number of black jellybeans?

Sample Responses to Discuss: Charles

The lid is round so the jar can be modeled as a cylinder.

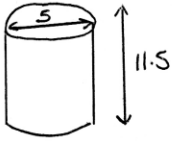

Volume of cylinder
 $= \pi \times 2.5^2 \times 11.5$

A jellybean can also be modeled as a cylinder with height 1.5cm and diameter 1cm

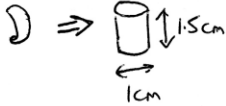

Volume of jellybean $= \pi \times 0.5^2 \times 1.5$

Number of jellybeans $= \frac{\text{vol. of cylinder}}{\text{vol. of jellybean}} = 191 \frac{2}{3}$

Can't have $\frac{2}{3}$'s of a Jellybean $\therefore = \underline{\underline{192}}$

I can see 2 sides of the jar and there are 7 black Jellybeans. There are 4 sides altogether so I guess the jar contains 14 black jellybeans.

What assumption has Charles made about the dimensions of the jar?

In what ways could Charles improve his work?

How Did You Work?

Complete the sentences and mark the boxes that apply to your work.

1. The method I used to complete the task on my own was:

.....
.....
.....

The method we used in our group was:

.....
.....
.....

The method I preferred was:

because:

.....
.....
.....

2. Our solution is similar to one of the sample responses

OR

Our solution is different from **all** the sample responses

Our solution is similar to

(add name of the sample response)

Our solution is different from **all** the sample responses because:

I prefer **our solution / the sample response** because:

.....
.....
.....

3. The assumptions we made were:

.....
.....
.....

Jellybean Guessing Contest

**Guessing
contest:**

How many
jellybeans are
in the jar?



Tie Breaker:

How many **black**
jellybeans are in
the jar?

Sharing Individual Solutions

1. Take turns to share with your partner(s) your own individual solution to the task and the notes you made on your mini-whiteboard about how you might improve your work.
2. Listen carefully to each other, asking questions if you do not understand.
3. Notice any similarities or differences between the methods described.

Joint Solution: Making Posters

1. In your group agree on the best method for completing the problem.
2. Produce a poster that shows a joint solution to the *Jellybeans* task, that is better than your individual work.
3. State on your poster any assumptions you have made.
4. Give clear reasons for your choice of method.

Sharing Posters

1. One person from each group get up and visit a different group.
2. If you are staying with your poster, explain your work to the visitor, giving reasons for your choice of method.
3. If you are the visitor, look carefully at the work, asking clarifying questions to help you to understand the method used.
4. Discuss whether or not the method described on the poster is similar to the visitor's method.
5. Compare your estimates for the total number of jellybeans in the jar and the number of black jellybeans.

Sample Responses to Discuss

1. Read each piece of sample student work carefully.
2. Try to understand what they have done. You may want to add annotations to the work to make it easier to follow.
3. Think about how the work could be improved. Take turns explaining your thinking to your partner.
4. Listen carefully and ask clarifying questions.
5. When your group has reached its conclusions, write your answers to the questions underneath the work.

Sample Responses to Discuss: James

One layer:

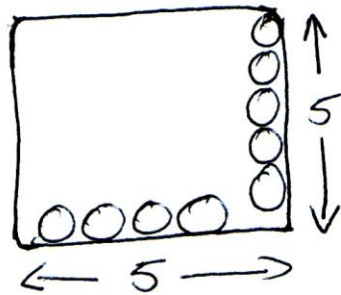

There are 7 layers like
this so

$$5 \times 5 \times 7 = 175$$

jelly beans

Where the jar narrows at the top
it is only 4×4 in a layer
so $4 \times 4 \times 2 = 32$

Total number of jelly beans =
 $175 + 32 = 207$

I can see 7 black jelly beans
in the jar.

Sample Responses to Discuss: Ruth

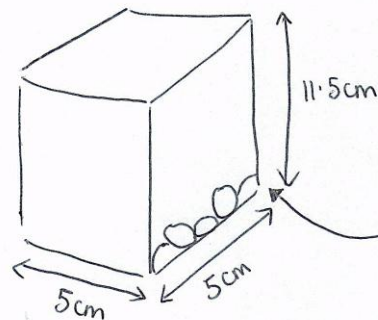

Volume of right rectangular prism
 $= 5 \times 5 \times 11.5 = 287.5 \text{ cm}^3$

Roughly 5 jellybeans fit along
this length so length of jellybean
 $= 1 \text{ cm}$.

The width and depth of the jellybeans are roughly
 $\frac{1}{2}$ the length so 0.5 cm

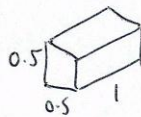

So volume of jellybean $= 0.5 \times 0.5 \times 1 = 2.5$

$$\frac{287.5}{2.5} = 115 \text{ jellybeans}$$

There are 9 different colours of jellybean so

$$\frac{1}{9} \times 115 \text{ will be black}$$

$$\hookrightarrow = 12.8 \text{ black jellybeans.}$$

Sample Responses to Discuss: Charles

The lid is round so the jar can be modeled as a cylinder.

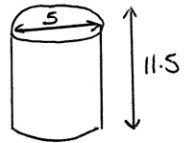

$$\begin{aligned}\text{Volume of cylinder} \\ &= \pi \times 2.5^2 \times 11.5\end{aligned}$$

A jellybean can also be modeled as a cylinder with height 1.5cm and diameter 1cm

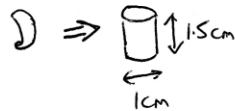

$$\text{Volume of jellybean} = \pi \times 0.5^2 \times 1.5$$

$$\text{Number of jellybeans} = \frac{\text{Vol. of cylinder}}{\text{Vol. of jellybean}} = 191\frac{2}{3}$$

Can't have $\frac{2}{3}$'s of a Jellybean $\therefore = \underline{\underline{192}}$

I can see 2 sides of the jar and there are 7 black Jellybeans. There are 4 sides altogether so I guess the jar contains 14 black jellybeans.

Mathematics Assessment Project
CLASSROOM CHALLENGES

This lesson was designed and developed by the
Shell Center Team
at the
University of Nottingham

**Malcolm Swan, Clare Dawson, Sheila Evans,
Marie Joubert and Colin Foster**

with

Hugh Burkhardt, Rita Crust, Andy Noyes, and Daniel Pead

It was refined on the basis of reports from teams of observers led by

David Foster, Mary Bouck, and Diane Schaefer

based on their observation of trials in US classrooms
along with comments from teachers and other users.

This project was conceived and directed for
MARS: Mathematics Assessment Resource Service
by

Alan Schoenfeld, Hugh Burkhardt, Daniel Pead, and Malcolm Swan

and based at the University of California, Berkeley

We are grateful to the many teachers, in the UK and the US, who trialed earlier versions
of these materials in their classrooms, to their students, and to
Judith Mills, Mathew Crosier, Nick Orchard and Alvaro Villanueva who contributed to the design.

This development would not have been possible without the support of

Bill & Melinda Gates Foundation

We are particularly grateful to

Carina Wong, Melissa Chabran, and Jamie McKee

© 2013 MARS, Shell Center, University of Nottingham
This material may be reproduced and distributed, without modification, for non-commercial purposes,
under the Creative Commons License detailed at <http://creativecommons.org/licenses/by-nc-nd/3.0/>
All other rights reserved.

Please contact map.info@mathshell.org if this license does not meet your needs.